

AHALTS ACCESS CONTROL SERIES

Model – AHALTS FB02



The AHALTS FB02 series flap barrier with two barriers and 6 pairs IR lights is designed to detect unauthorized entrance or exit.

- Integrated with the access control system, person should authenticate to pass through the lane via swiping card, scanning QR code, etc. It is widely used in attractions, stadiums, construction sites, residences, etc.
- Permissions validation and anti-tailgating.
- Remaining open/closed mode selectable.
- The barrier will be open or stop working when people are nipped.
- Self-detection, Self-diagnostics, and automatic alarm.
- Audible and visual alarm will be triggered when detecting intrusion, tailgating reverse passing, and climbing over barrier.
- TCP/IP network communication: The communication data is specially encrypted to relieve the concern of privacy .
- LED indicates the entrance/exit and passing status.
- Fire alarm passing: When the fire alarm is triggered, the barrier will be open automatically for emergency evacuation.

AHALTS ACCESS CONTROL SERIES

Specification

System	
MCBF	> 3 million times
Motor	Brush motor
Interface	
Network interface	1
RS-485	4
RS-232	4
Lock output	2
IO input	2
IO output	2
Capacity	
Card capacity	60,000
Event capacity	180,000
General	
Throughput	20 to 60 persons per minute The actual throughput is affected by the person passing rate and passing method
Power supply method	100 to 240 VAC, 50 to 60 Hz
IR light detectors	6 pairs
Working temperature	-20 °C to 65 °C (-4 °F to 149 °F)
Lane width	600 mm (23.62")
Working humidity	0% to 95% (No condensing)
Barrier material	Acrylic glass
Dimensions	1207 mm × 315 mm × 990 mm (47.52" × 12.40" × 38.98")
Pedestal material	stainless steel
Application environment	Indoor and outdoor
Weight	Net: approximately 50 kg (left)/64 kg (middle)/52 kg (right) (110.3 lb/141.1 lb/114.7 lb)
Configuration	
Module selection	YES
Authentication mode	Card, Face, Fingerprint, QR code
Card type	EM, M1
Wall distance	10 mm
Lane width	600
Recommended width	600
Pedestal length	1200 mm
Pedestal width	315 mm
Barrier material	Acrylic glass

AHALTS ACCESS CONTROL SERIES

Dimension

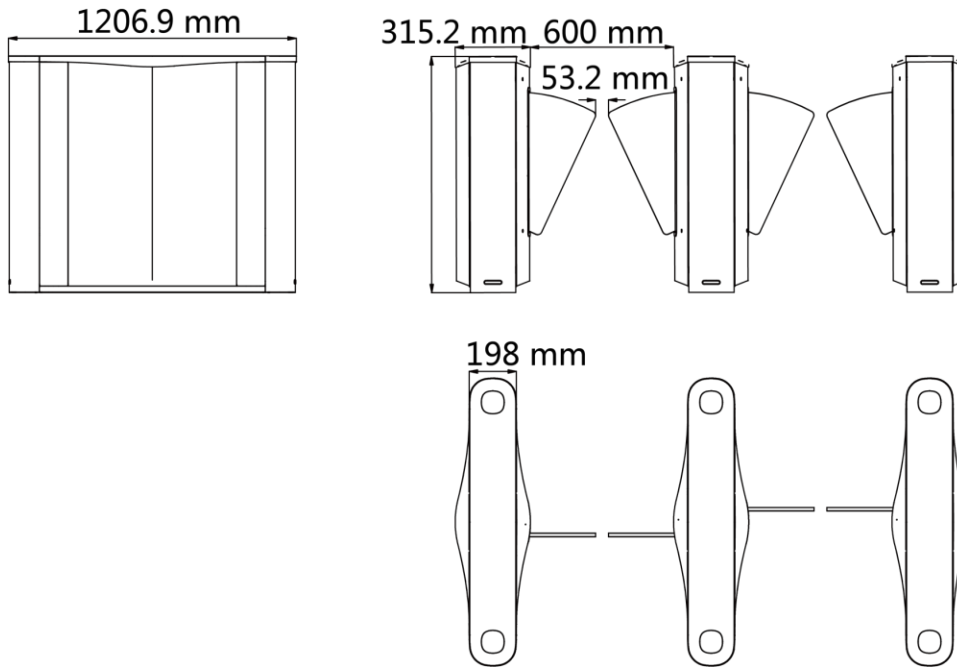

Tip Top Platform Pvt. Ltd.

A-3, Sardar Patel Marg, C Scheme, Jaipur, Rajasthan, India 302001

Website: www.ahalts.com

Branch – INDIA, UAE